

Set-up guide

Fibre to the Curb FTTC

Box contents

Box 1 (Brown)

- 1 x nbn™ connection device
- 1 x nbn™ power cable
- 1 x nbn™ telephone cable

Box 2 (Coloured Sleeve)



- 2 x Ethernet cables
- 1 x Wi-Fi Modem
- 1 x Power adaptor
- 2 x Phone cable

1. Set up the nbn connection device - Box 1

a.

Once we've got in touch (via SMS or email) to let you know that you're ready to connect, use the following instructions to plug in the cables.

b.

Once it's all plugged in, wait 15 minutes. You'll know it's ready when the  connection light and  broadband light turn solid blue.

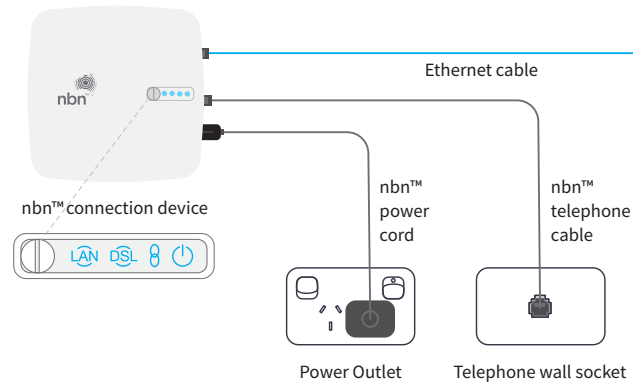

2. Set up your supplied Wi-Fi modem - Box 2

There are more comprehensive instructions inside your Wi-Fi modem box

a.

Use the following instructions to plug in the cables.

b.

When you're all plugged in, switch on your modem and wait 15 minutes while it configures.

c.

When the first four lights have switched on, you're all connected.

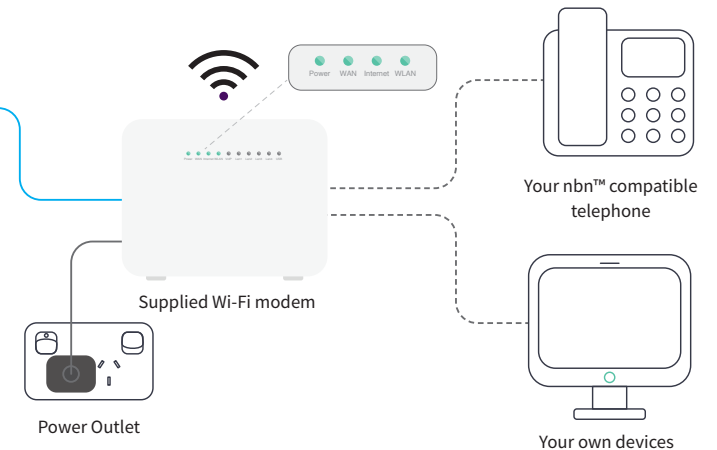

No solid blue lights?

Check all cables are securely plugged into the nbn™ connection device and at the wall.

Still not working after 15 minutes?

If the lights are still not blue try connecting the nbn™ connection device to a different telephone wall socket.

If this doesn't work, you can contact us using one of the options on your modem sleeve.



3. Connect your devices

You can choose to connect your devices to the Internet via Wi-Fi or Ethernet cable. There are instructions on how to connect devices and phone services in the supplied Set-up Guide inside your Wi-Fi modem box.